















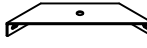

No	Part	Qty
1	Head board	1
2	Right Bedside	1
3	Left Bedside	1
4	Foot Board	1
5	Bed Support	2
6	Bed board	3

HARDWARE FOR BED			
No	Part		Qty
A	 	M6x18	16
B		Cover Cap $\phi 50$	8
C		Threaded Bolt M8x70	4
D		Spanner M8/13mm	1
E		Nut M8	8
F		Maxiluna Washer $\phi 40 \times 15$	8
G		Threaded Bolt M8x70	4
H		Spanner (5mm)	1
I		Gasket M8	4
J		Angle Iron	2
N		Junction box	1

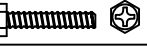
HARDWARE FOR BEDSUPPORT			
No	Part		Qty
K		Nut M6	8
L		Screw M6x45	8
M		Gasket M6	16

- Please check contents and read instructions before commencing assembly.
- Please use a soft mat to avoid damaging during assembly
- Assemble this article following the enclosed instructions carefully.

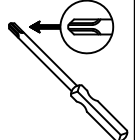
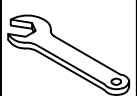
	 30min		 X1
---	--	---	---

STEP 1

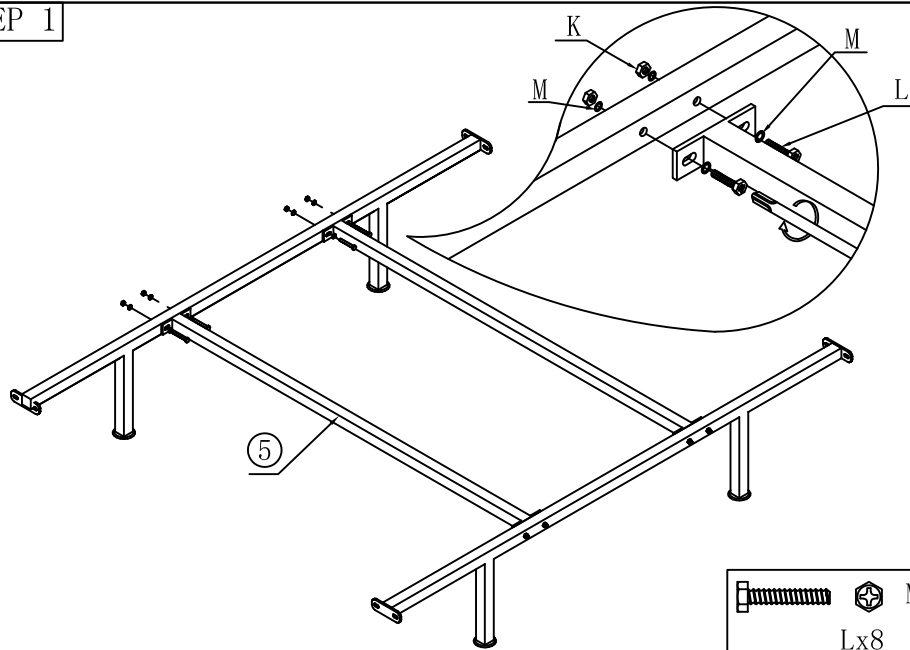

		M6x45
		Lx8
	Nut M6	
Kx8		
	M6	
		Mx16

STEP 2

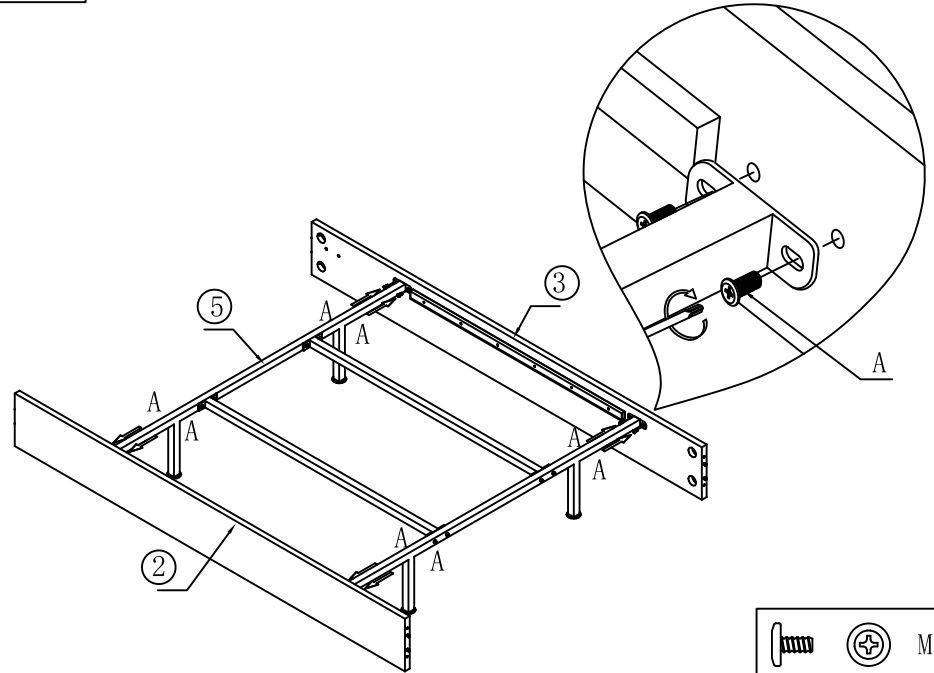

		M6x18
		Ax8

STEP 3

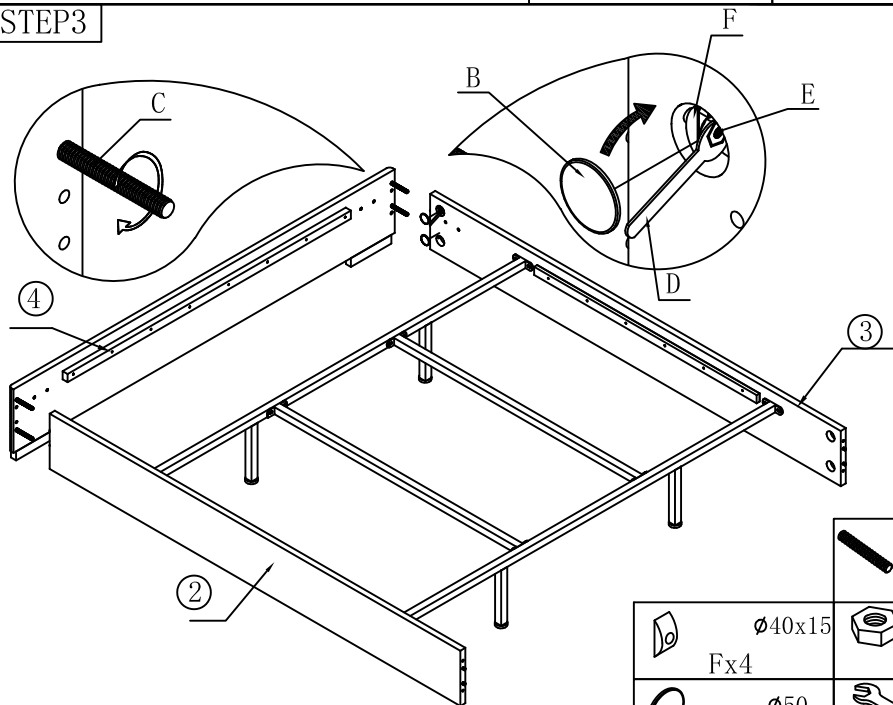

	M8x70
Cx4	
	$\phi 40 \times 15$
Fx4	Nut M8
	Ex4
	$\phi 50$
Bx4	M8/13mm
	Dx1

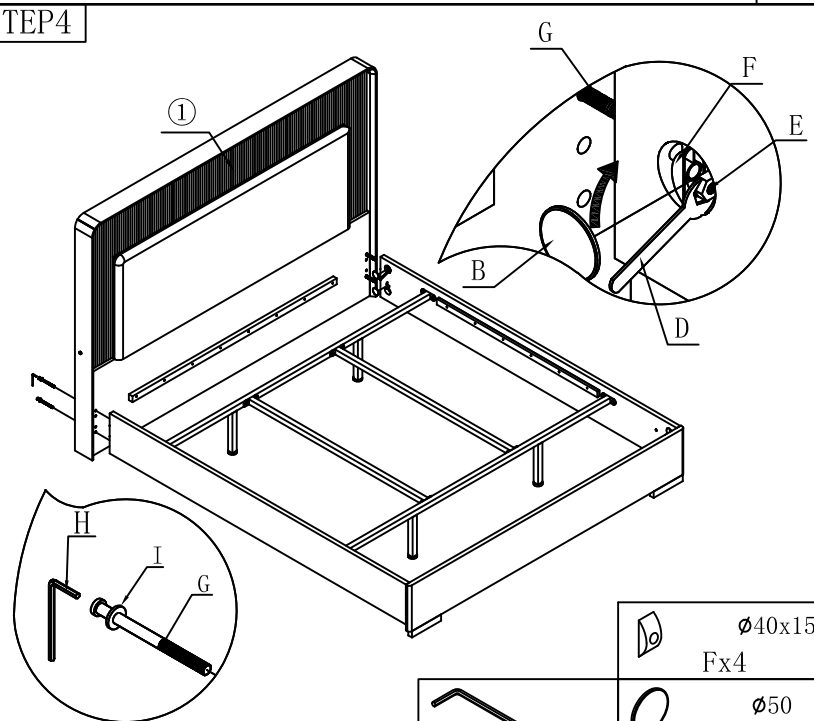

STEP 4

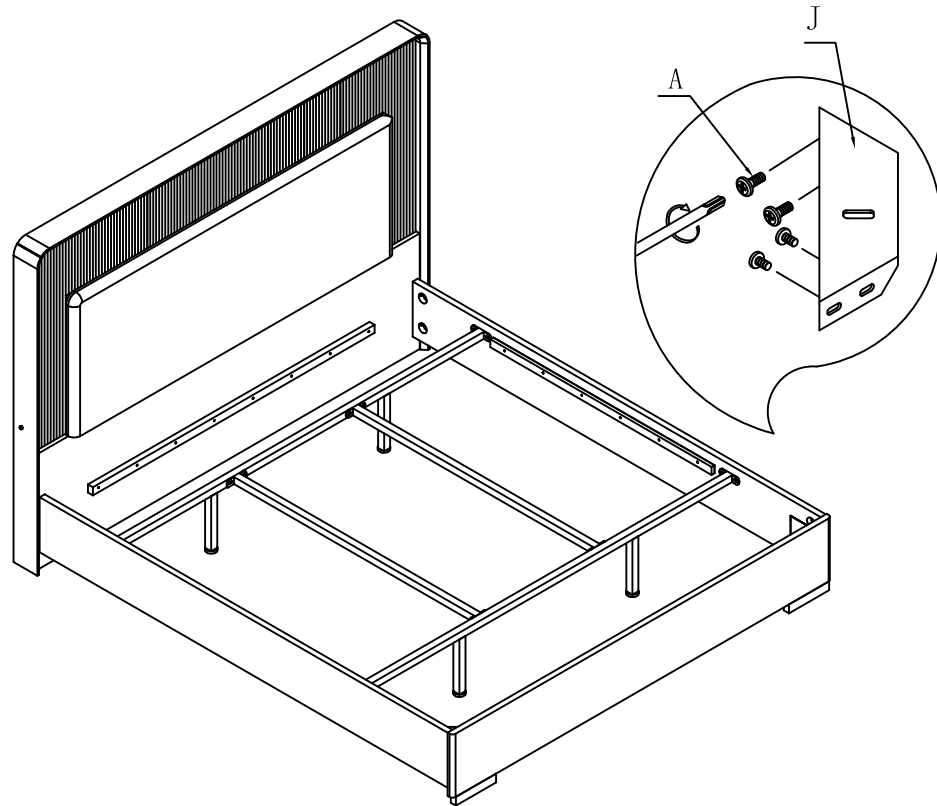

	Gasket M8
Ix4	
	M8x70
Gx4	
	$\phi 40 \times 15$
Fx4	Nut M8
	Ex4
	$\phi 50$
Bx4	M8/13mm
	Dx1
	Hx1

STEP5



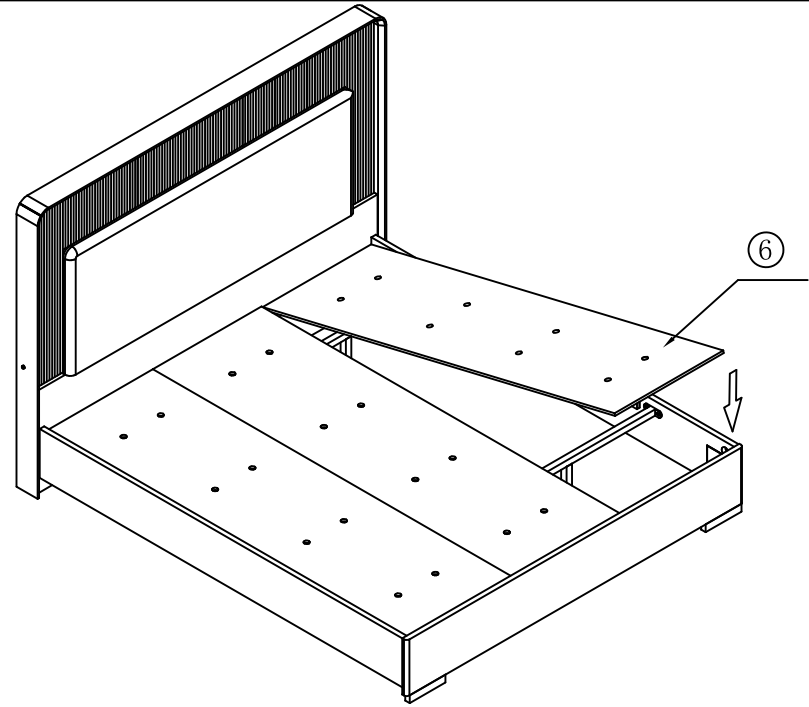

	Angle Iron		M6x18
Jx2		Ax8	

STEP6

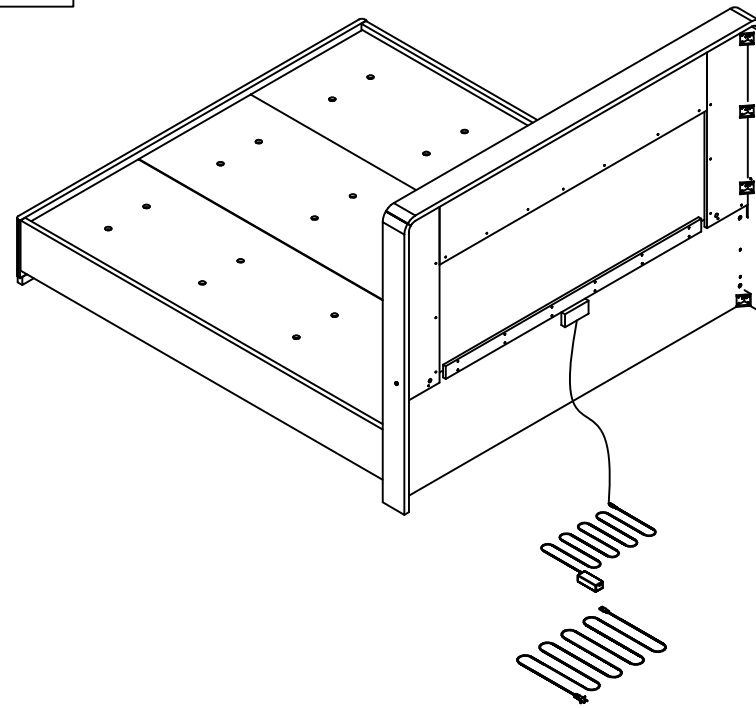

STEP7



	Junction box
Nx1	