

ASSEMBLY INSTRUCTION
KF.A2589

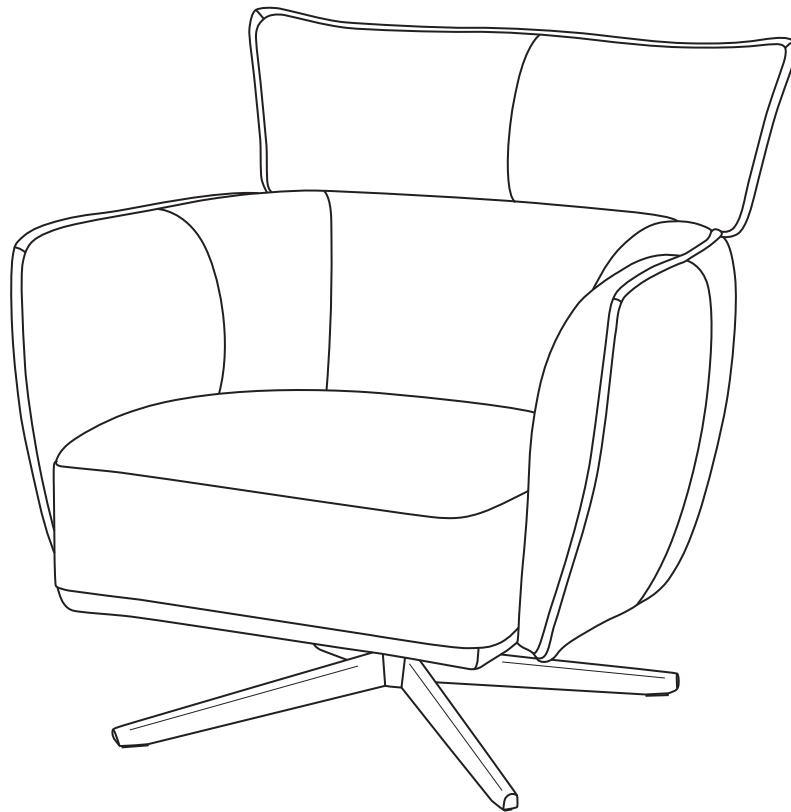

Thank you for purchasing this quality product. Be sure to check all packing material carefully for small parts which may have come loose inside the carton during shipment. Identify and count all parts and compare with the parts list below:

Part List:

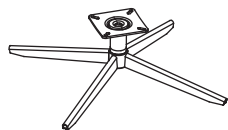

A x 1

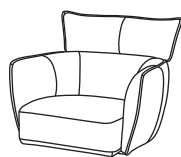

B x 1

Hardware List:

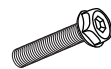

(M8x30mm)

H1 x 4



T1 x 1

Assembly Instruction:

Step 1: 将椅座软包倒放在柔和、干净、平整的水平面上，再将金属转盘脚倒放在椅座底部，对应好安装孔，并通过螺杆(H1x4)和内六角扳手(T1)顺时针拧紧固定。

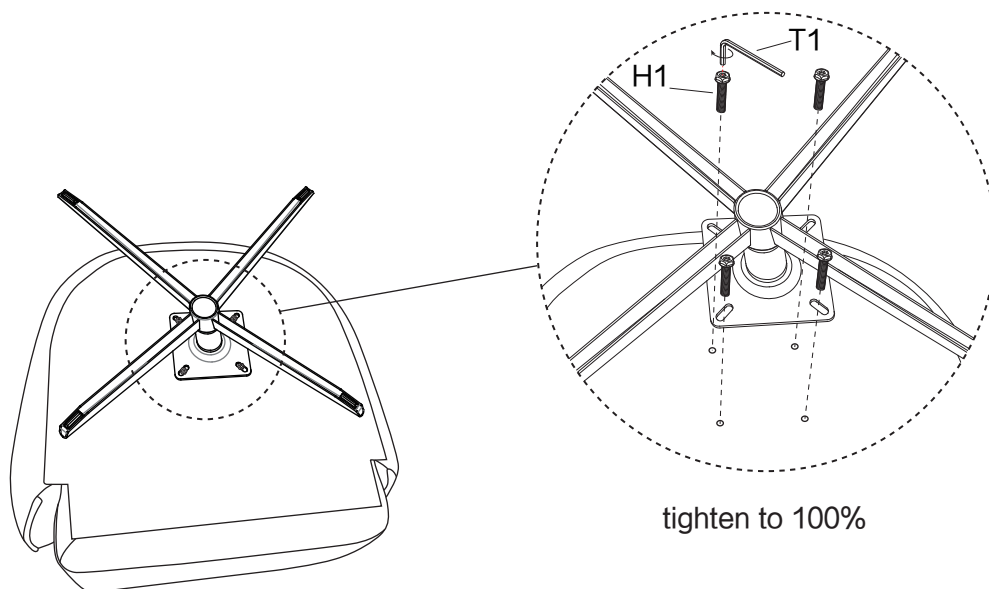

Step 2: 组装完成.

