

No	Part	Qty
1	Head Board	1
2	Right Bedside	1
3	Left Bedside	1
4	Foot Board	1
5	Drawer front panel	1
6	Drawer side panel	2
7	Drawer back panel	1
8	Drawer bottom panel	1
9	Center panel	1
10	Bed Support	1
11	Bed board	2

No	Part	Qty
A	Angle iron	2
B	Spanner M8/13mm	1
C	Threaded Bolt M8x70	4
D	Screw M6X18	16
E	Maxiluna Washer $\phi 40 \times 15$	4
F	Cover Cap $\phi 50$	4
G	Nut M8	4
H	Quickfit ( $\phi 5 \times 33$ )	26
I	Cam $\phi 15 \times 12$	26
J	Foot wheel	6
K	Screw $\phi 4 \times 14$	12
L	No-bump plastic 1MM	4
M	bedside bumper	2
N	Screw $\phi 4 \times 16$	6
O	Junction box	1

HARDWARE FOR BEDSUPPORT

P	Screw M6x45	8
Q	Gasket M6	16
R	Nut M6	8

  
 Please check contents and read instructions before commencing assembly.  
 Please use a soft mat to avoid damaging during assembly  
 Assemble this article following the enclosed instructions carefully

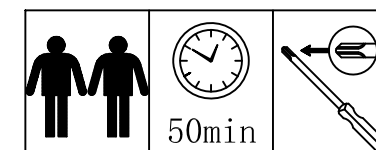

50min

STEP 1

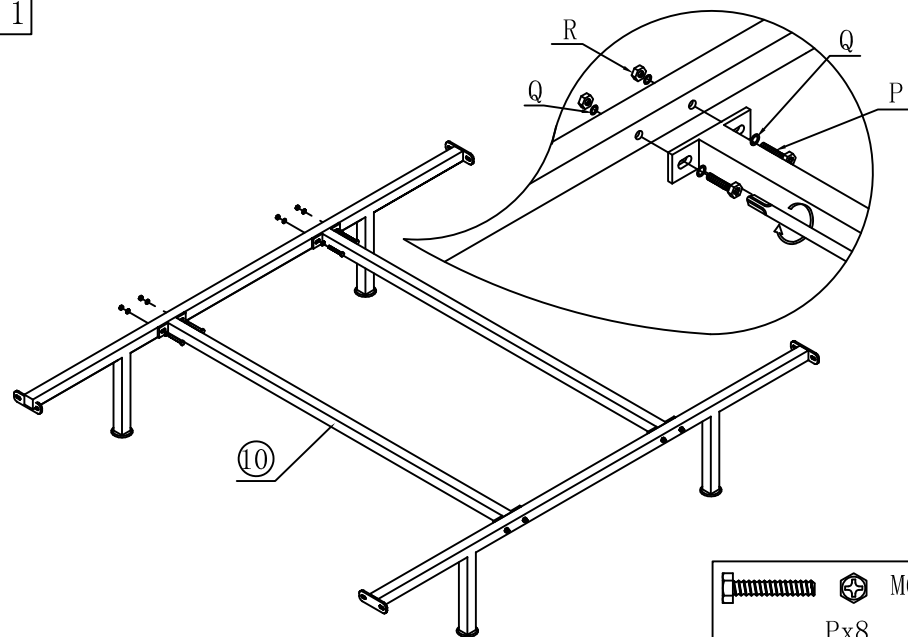

		M6x45
		Px8
	Nut M6	
	Rx8	
		M6
		Qx16

STEP 2

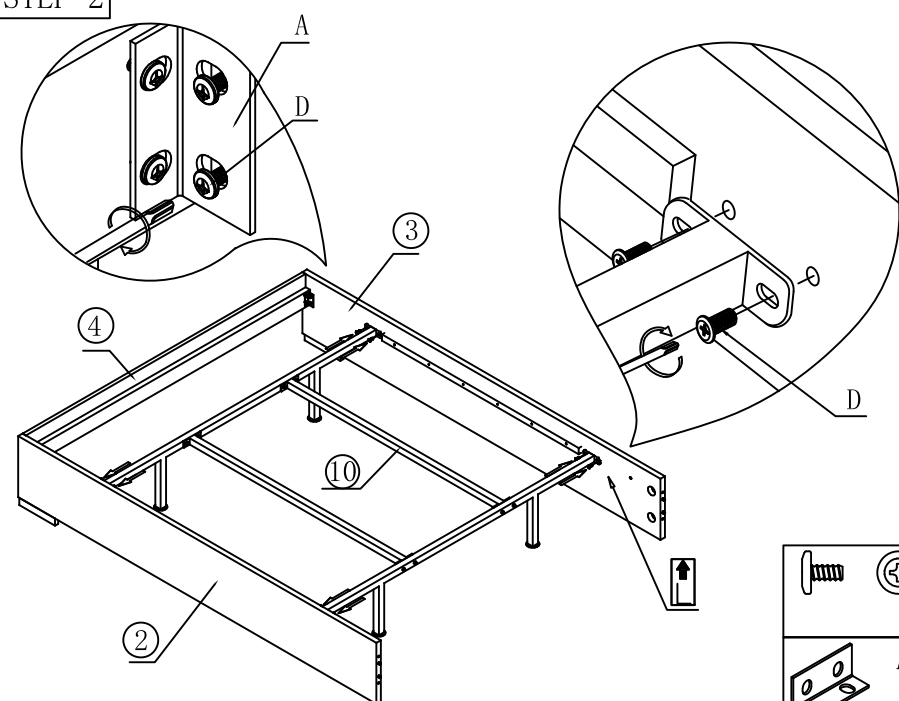

		M6x18
		Dx16
	Angle iron	AX2

STEP 3

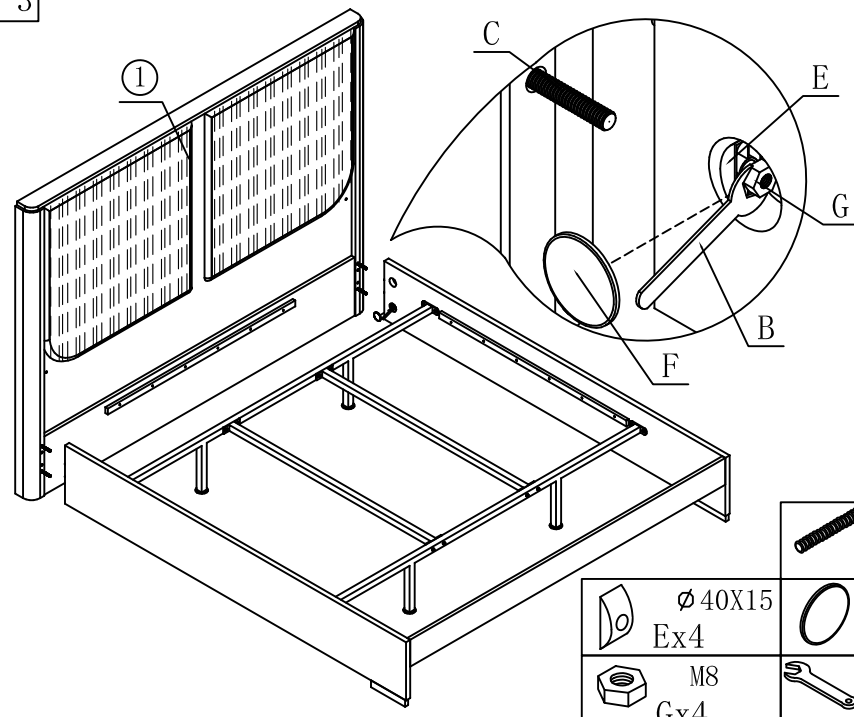

	M8x70
	Cx4
	∅40X15
	Ex4
	M8
	Gx4
	∅50
	Fx4
	M8/13mm
	Bx1

STEP 4

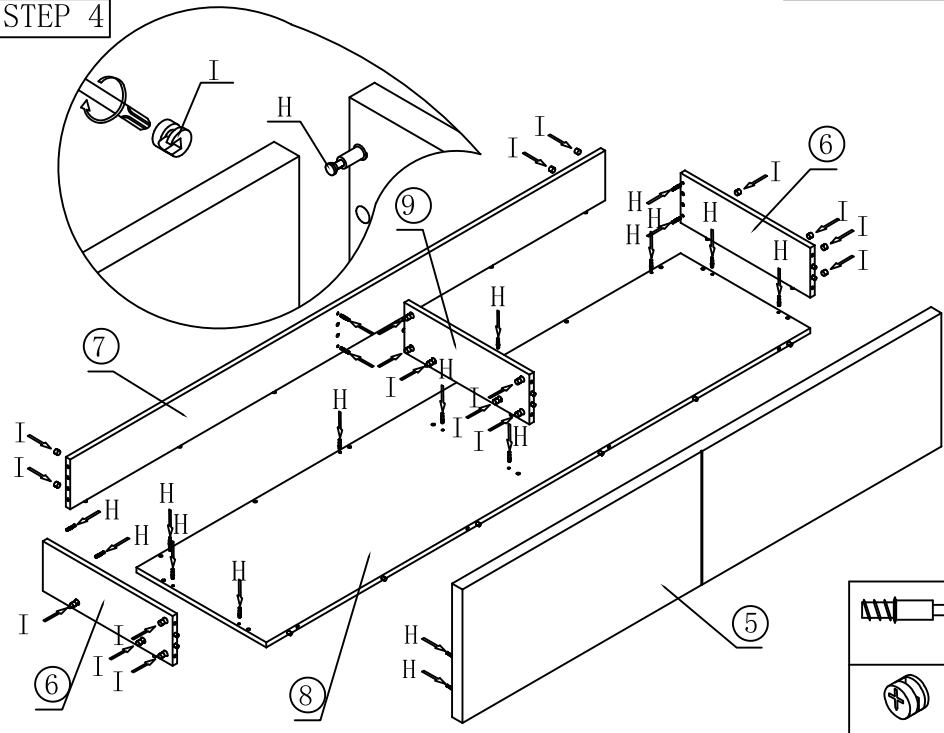

	∅5X33
	Hx26
	∅15X12
	Ix26

STEP 5

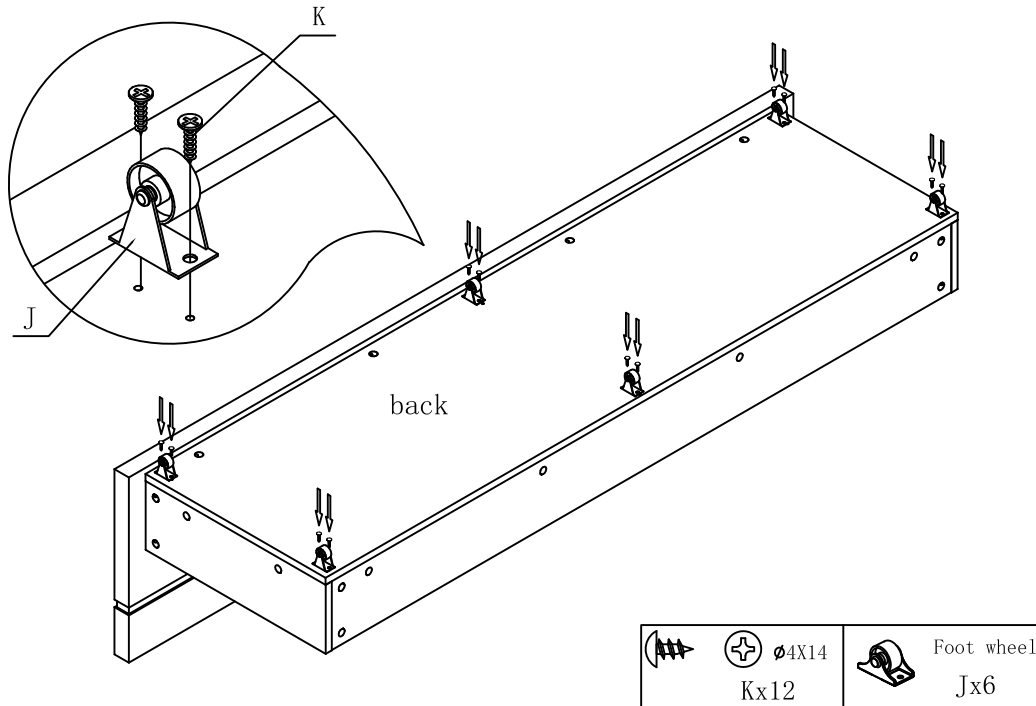

STEP 6

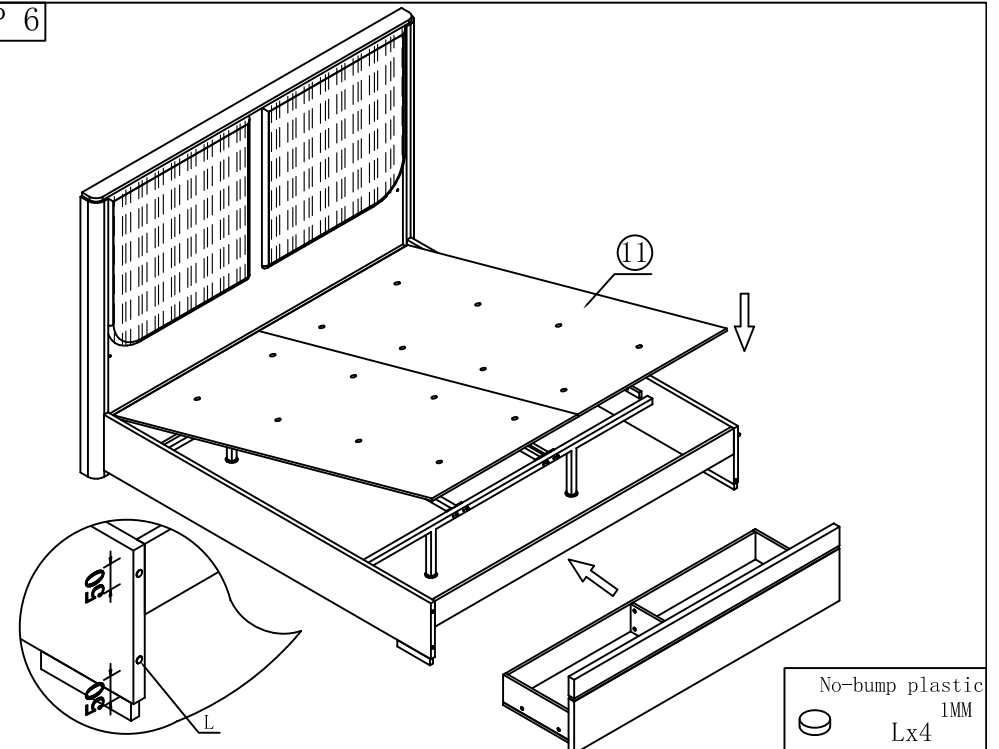

STEP 7

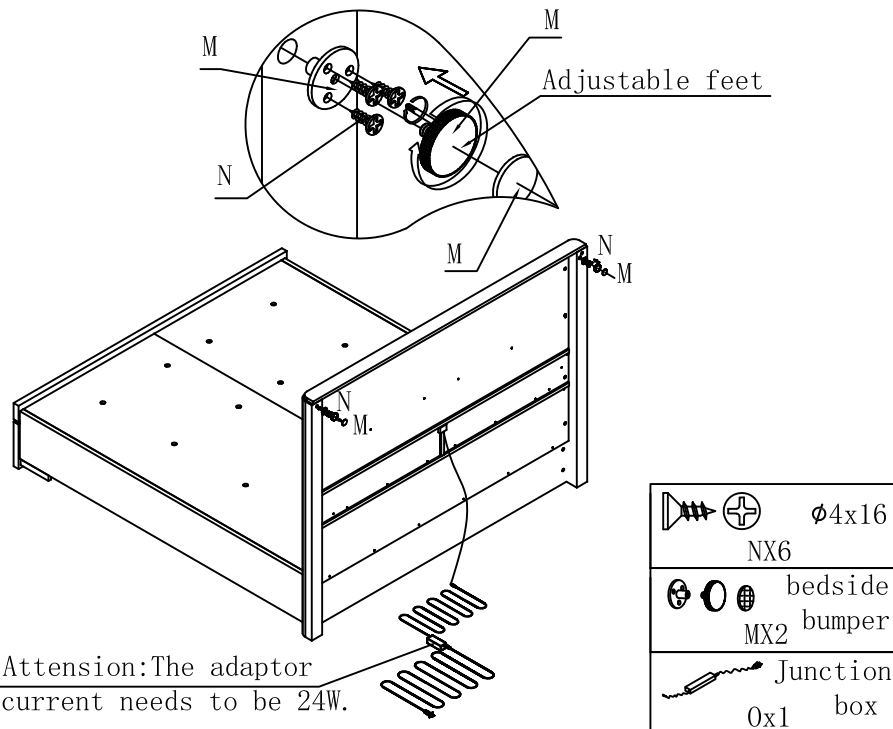

Attention: The adaptor current needs to be 24W.

STEP 8

