









PLEASE FOLLOW UP WITH BELOW STEPS WHEN ASSEMBLE THE BED.

Step 1 – Assemble the side rails to bed head and bed end.

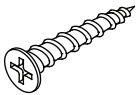
Step 2 – Turn frame onto side panel and screw 4 legs onto the corners.

Step 3 – Assemble middle support rails.

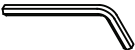
Step 4 – Assemble slats.

<p>Ax20 M8x30mm</p> 	<p>Bx4 M8x35mm</p> 	<p>Cx16</p> 	<p>Dx4 M8</p> 	<p>Ex8</p> 	<p>Fx16</p> 
<p>Gx1</p> 	<p>Hx1</p> 				

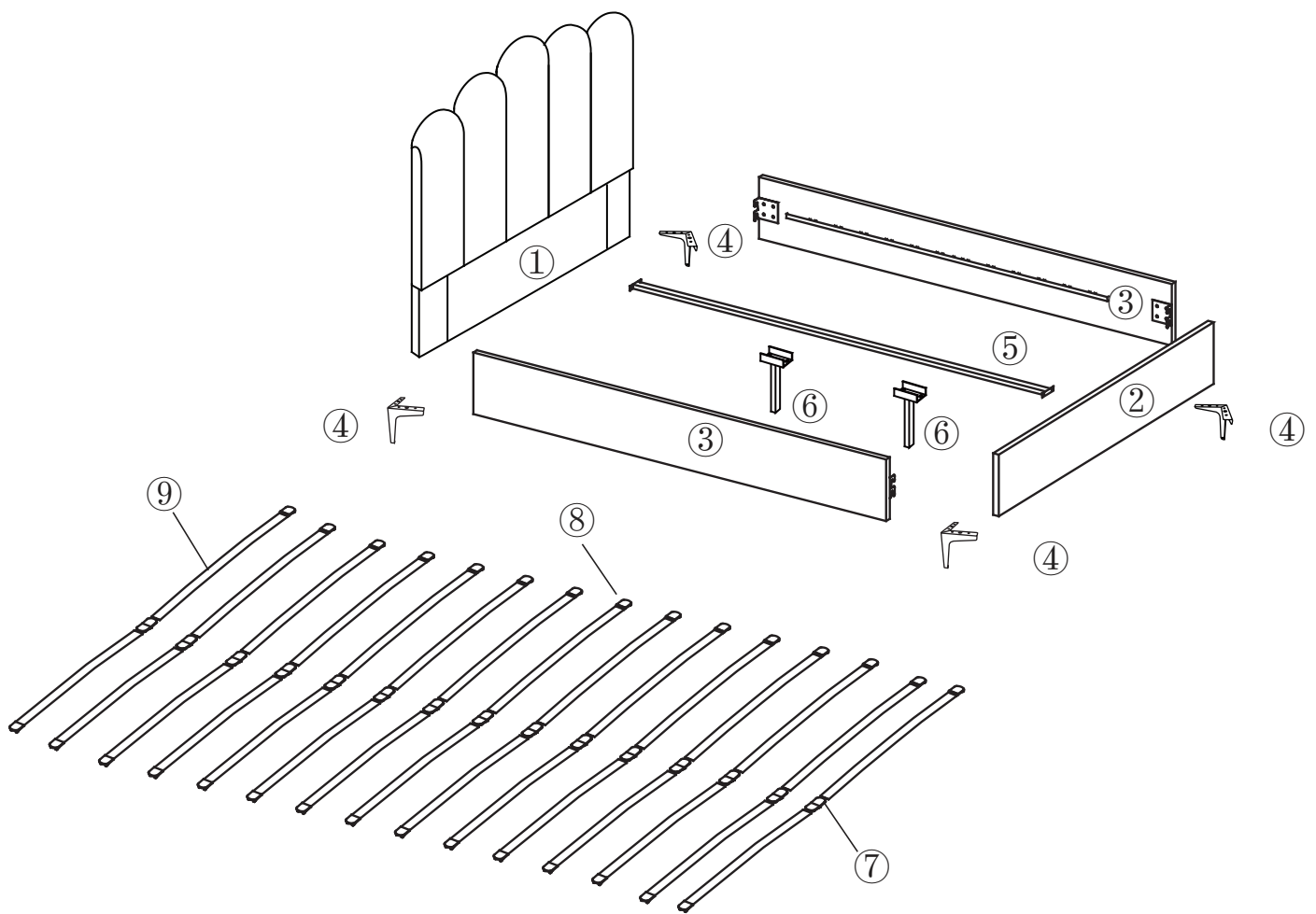

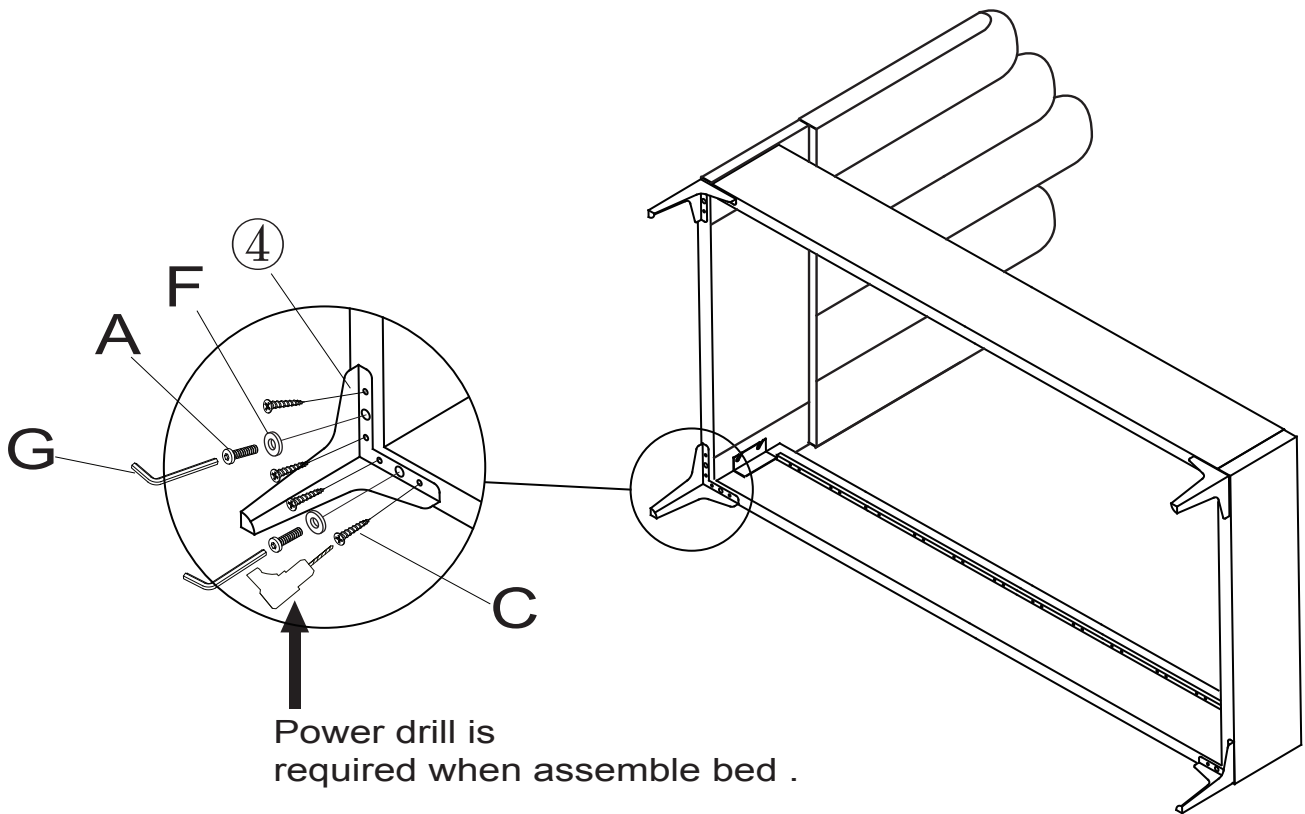
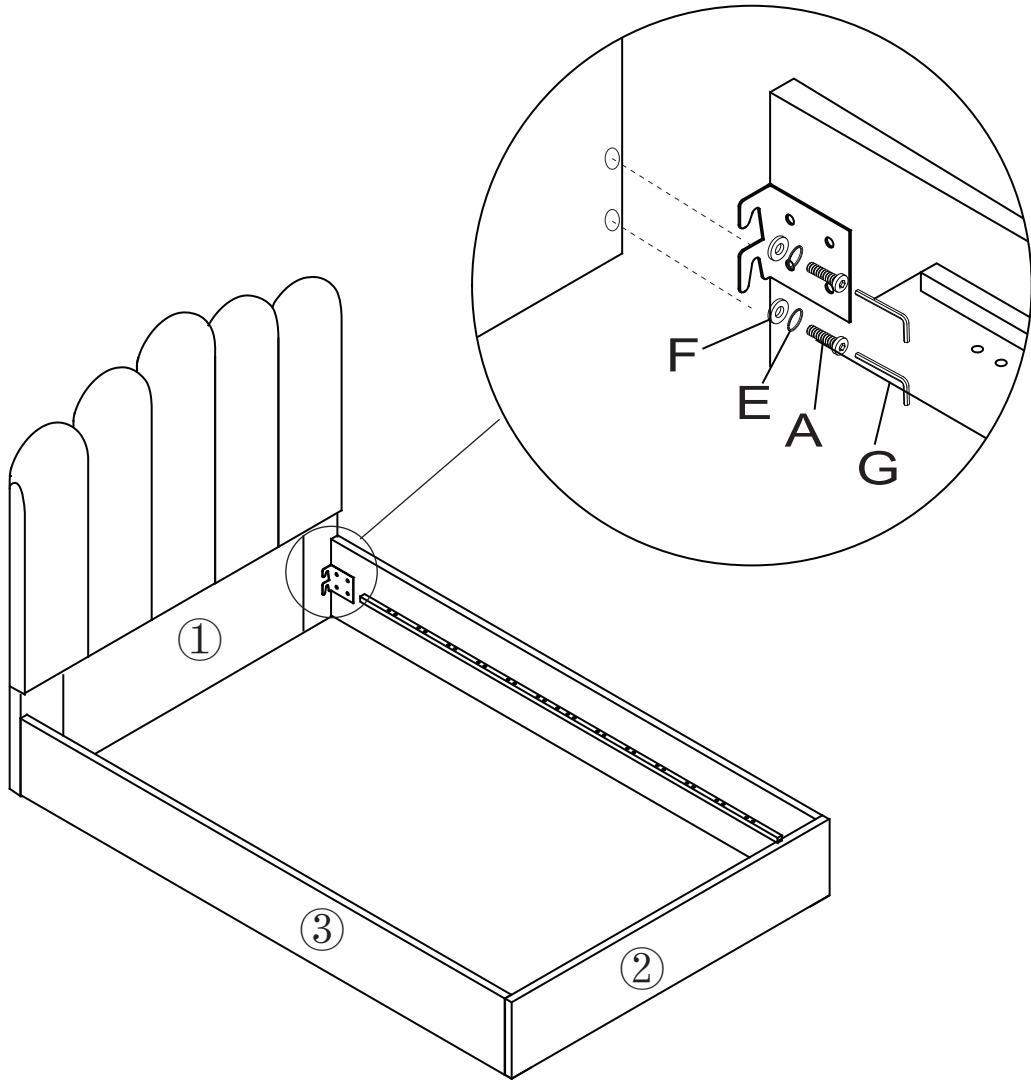

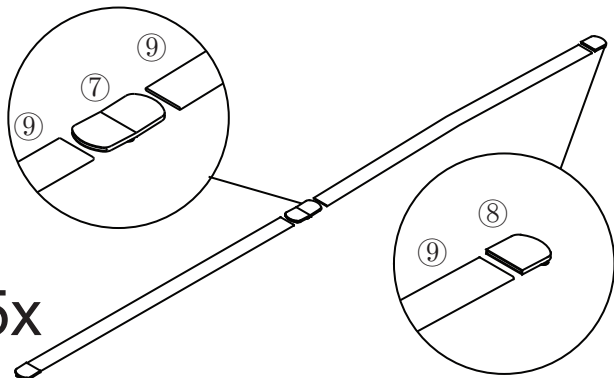
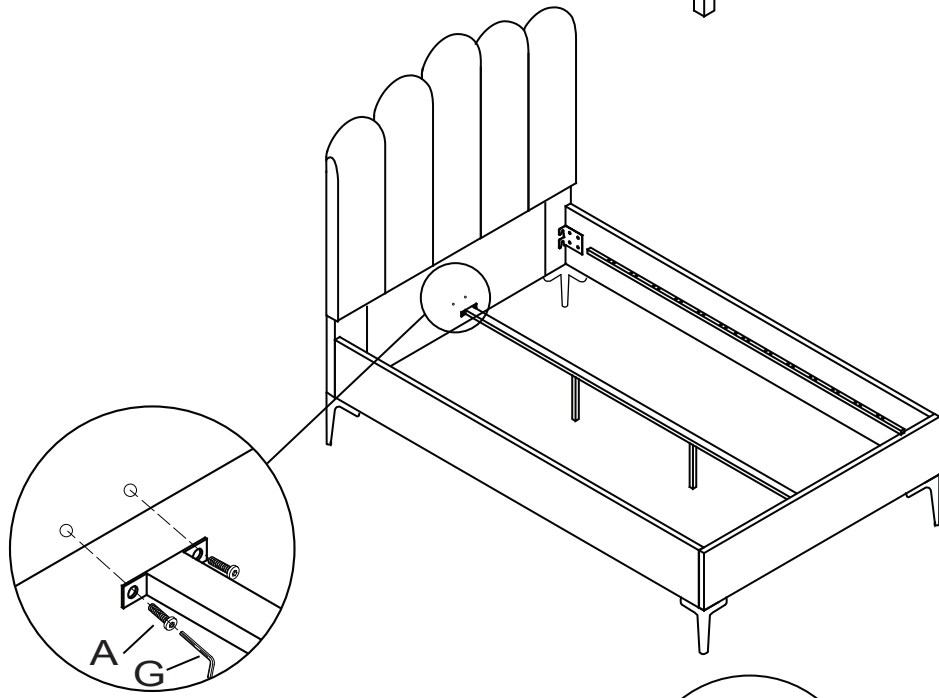
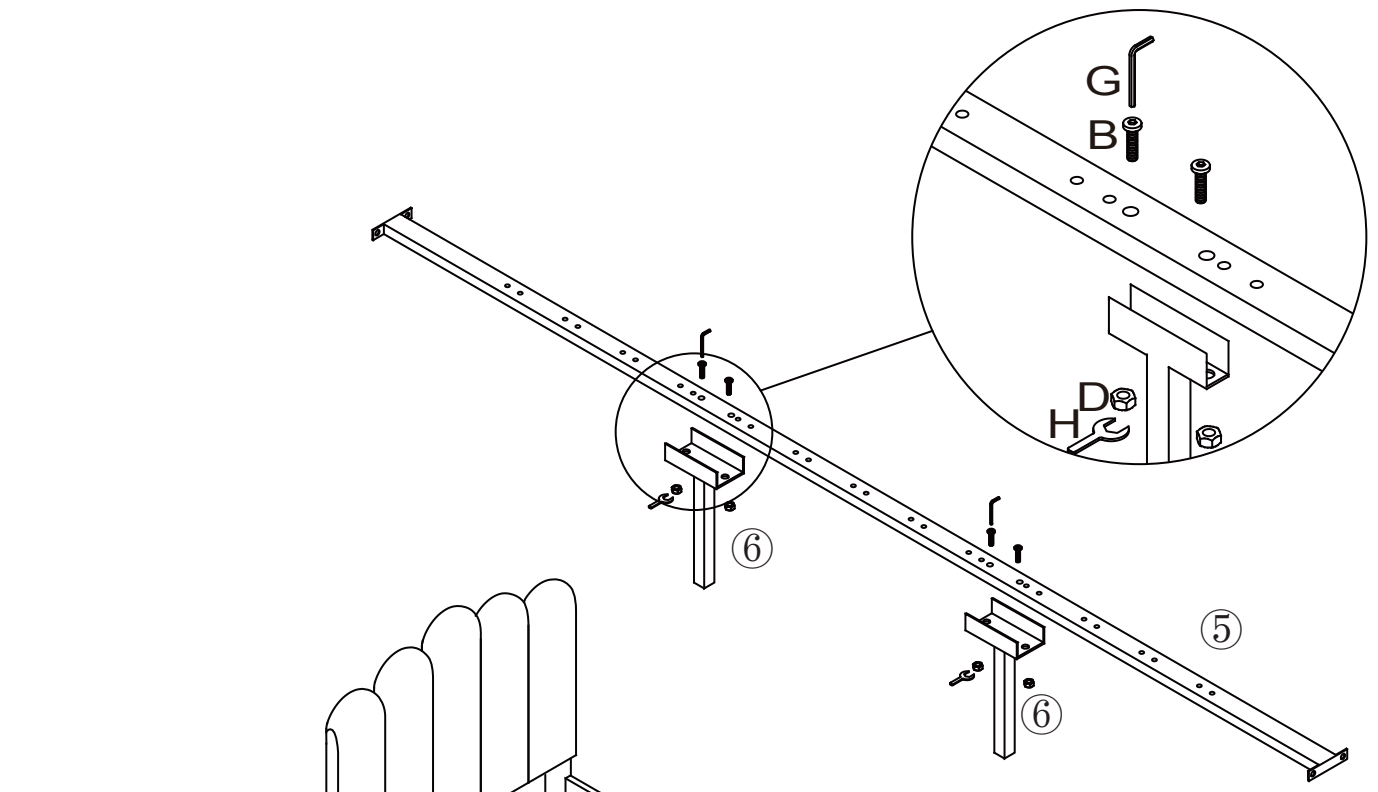

15x

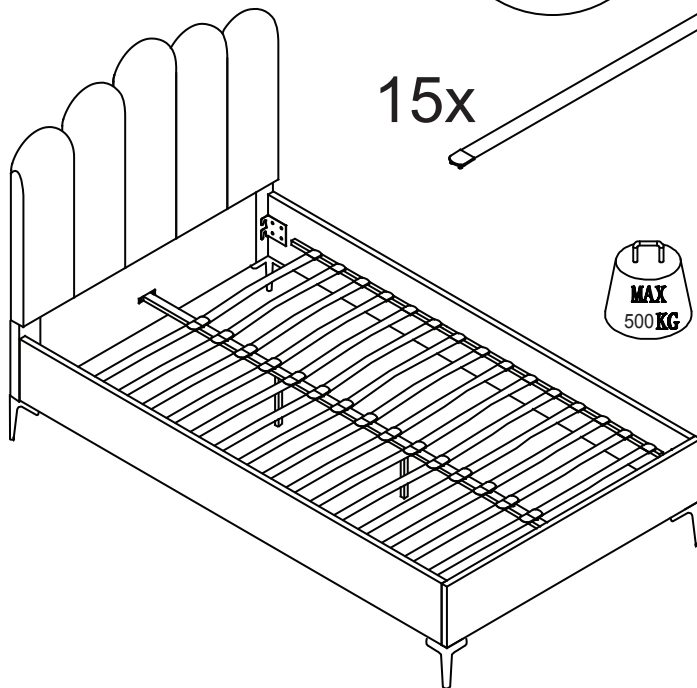

MAX
500KG